

Tutti i diritti riservati. Questo disegno e parti di esso non possono essere riprodotti, usati o resi noti in alcun modo o terzi senza autorizzazione della WBT Srl
 All rights reserved. This drawing or parts of it cannot be reproduced or copied or modified in any form or by any means, graphic electronic or mechanical, including photocopying without the written permission of WBT Srl

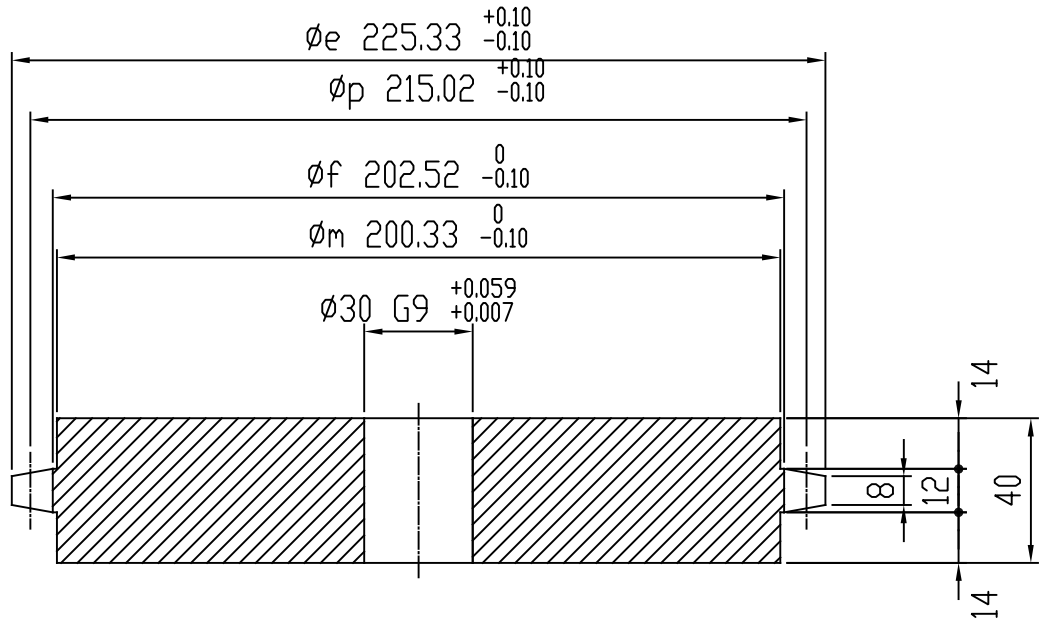
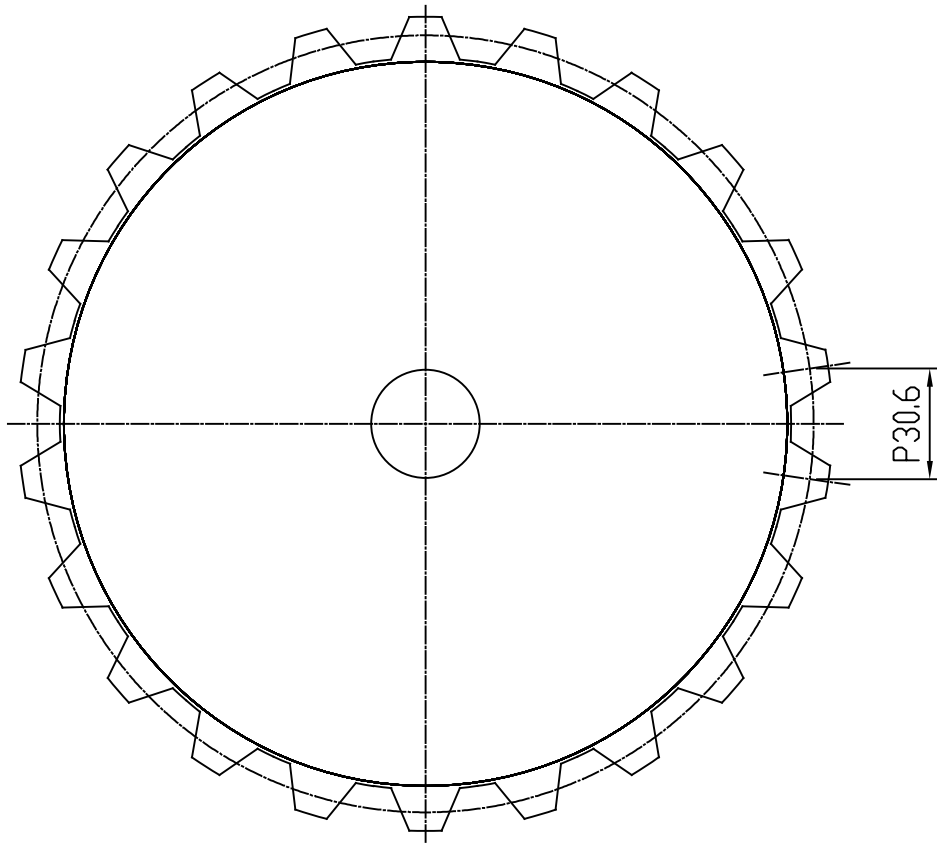
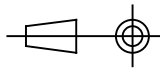

0	0	RD040306002237ST0062	C45		
Pos.	Q.ta'	Denominazione	Materiale	Trattam.	UNI / note
WBT SRL Via XXV Aprile, 2 23804 MONTE MARENZO (LC) P.IVA/C.F. 03373740137 Tel 0341-632080 Fax 0341-588818				Scala	1:1
				Disegnato da	F.G.
				Data	22/02/2019
Ruota dentata P.30,6 Z=22 ϕ_p 215,02 Foro $\phi 30$ G9 Ld.12/8 Sp.tot.= mm40				 sistema E	
				DISEGNO N°	Rev. 0
Rev. 3	Rev. 2	Rev. 1			